

# System Technology, Inc.

20655 S. Amherst Court  
Joliet, Illinois 60433-9716  
Phone: (815) 726-6700  
Fax: (815) 726-6740  
<http://www.systemtechnologyinc.com>



## PD07 AUTOMATIC PALLET DISPENSER

Featuring In-Line Auto Loading and Enhanced Standard Design

STI's pallet dispenser is **auto loading**, which can streamline your palletizing operation. With enough zones for feeding stacks of empty pallets into the dispenser, machines can be loaded to run an entire shift unattended.

### Standard Features:

- In-Line Auto Loading
- Automatic Self Centering
- Load Pallets With Long Or Short Edge Leading
- Unattended Operation With Stack Light Alert
- Automatic Dispensing Of CHEP Rental, And GMA And Other Pallet Sizes
- Discharges In Any Direction
- Complete Turnkey Package With PLC Programming
- Dry Contacts For System Integration
- Heavy Duty Tubular And Formed Steel Construction
- Simple, Compact Design For Tight Spaces
- Electric Lifting System Provides Smooth, Reliable Performance
- Safety Guarding And Controls
- Photo Eye Control Of Stack Height
- Standard 4-Week Delivery

### Optional Features:

- Stacker Function
- Pallet Conveyor Available
- Increased Lifting Capacity
- UL Certification
- Other Customization Available

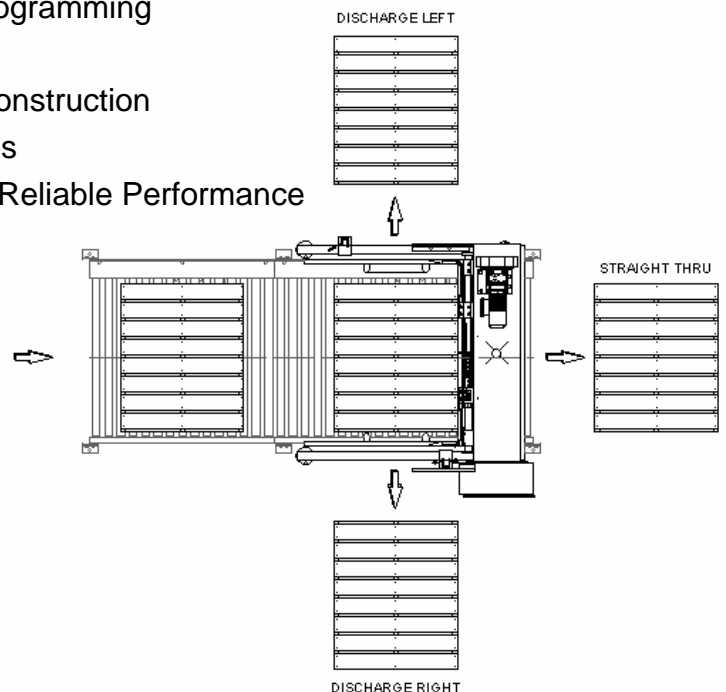

Dispenses in any direction

# PD07 AUTOMATIC PALLET DISPENSER

## Equipment Specifications

<b>Pallet Size</b>	Minimum: 37" Maximum: 53"
<b>Pallet Type</b>	2-Way, 4-Way, Wing, Block, Expendable, Chep, GMA, Plywood, Plastic, Aluminum & Display ( <i>call for other pallet styles and sizes</i> )
<b>Dispensing Rate</b>	Four pallets per minute (max)
<b>Discharge Configurations</b>	Left hand, right hand and in-line
<b>Maximum Lifting Capacity</b>	1,100 lbs
<b>Maximum Capacity</b>	15 pcs (@ 5" high pallet each)
<b>Top View Footprint</b>	74" x 82"
<b>Maximum Height</b>	115"
<b>Shipping Height</b>	84"
<b>Electrical Requirements</b>	460 VAC, 3 ph, 60 hz (standard) 230 VAC, 3 ph, 60 hz (optional) 575 VAC, 3 ph, 60 hz (optional)
<b>Machine Control Voltage</b>	24 VDC
<b>Programmable Controller</b>	Allen-Bradley Micrologix 1200
<b>Pneumatic Requirements</b>	5 SCFM @ 80 PSI clean, dry air

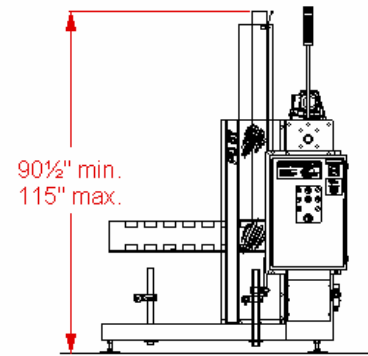

SIDE VIEW

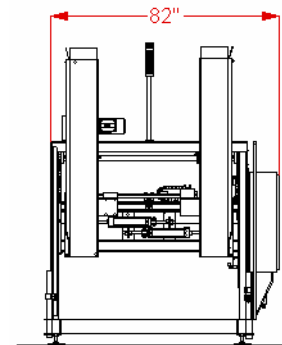

FRONT VIEW

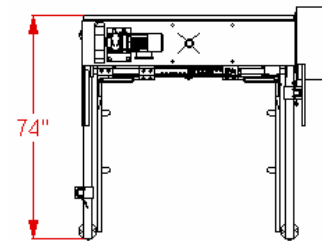

TOP VIEW

### *System Technology, Inc.*

20655 S. Amherst Court  
Joliet, Illinois 60433-9716  
Phone: (815) 726-6700  
Fax: (815) 726-6740

[www.systemtechnologyinc.com](http://www.systemtechnologyinc.com)

