

System Technology, Inc.

20655 S. Amherst Court
Joliet, Illinois 60433-9716
Phone: (815) 726-6700
Fax: (815) 726-6740
<http://www.systemtechnologyinc.com>



IN08 AUTOMATIC CASE INDEXER Enhanced Standard Design

Standard Features:

For precise positioning of conveyed containers.
Ideal for case filling operations.

Holds one case in position, while restraining next case in line.

Wash-down suitable, stainless-steel construction.
3-week delivery.

Optional Features:

Control Solenoid & Regulator

Larger or smaller case sizes available;
contact STI for more details.

Photoeyes and controls.



Case Width Adjustability	Quick adjustment handles permit width adjustment +/- 6" from nominal
Case Length Adjustability	Length adjustments can be made +/- 3" from nominal
Dispensing Rate	Will keep pace with your conveyor
Resisting Force	Will resist up to 100 lbs of force
Length	40"
Pneumatic Requirements	5 SCFM @ 80 PSI clean, dry air

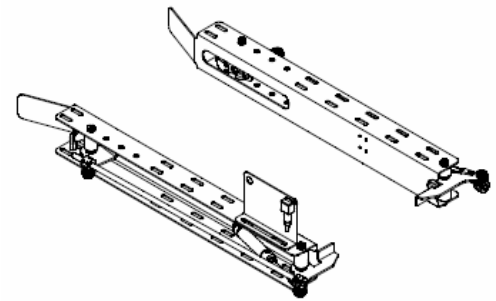

3-D VIEW



+/- 6" FROM NOMINAL

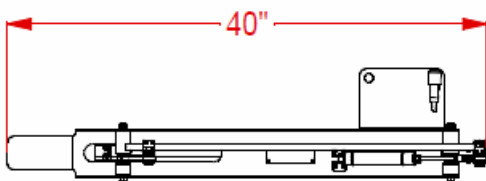

SIDE VIEW



TOP VIEW